

CAD FILE:

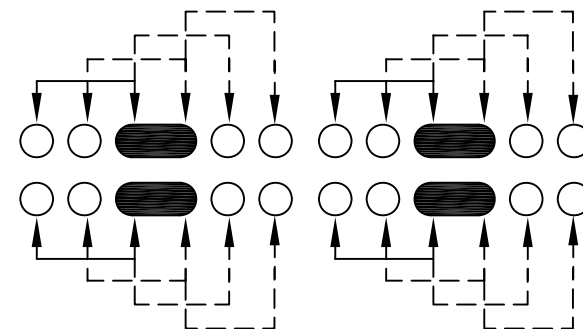

SCHEMATIC (SHORTING)

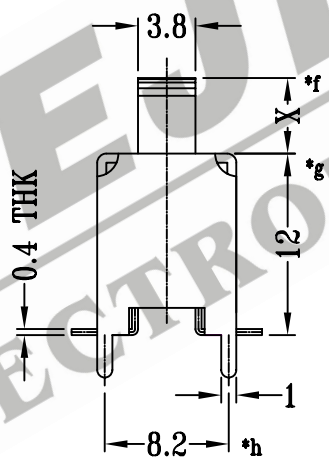
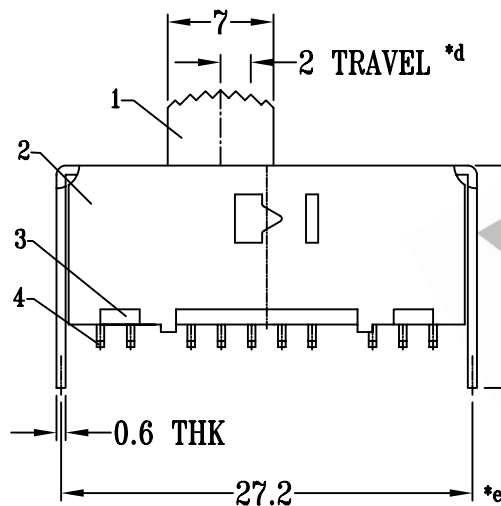
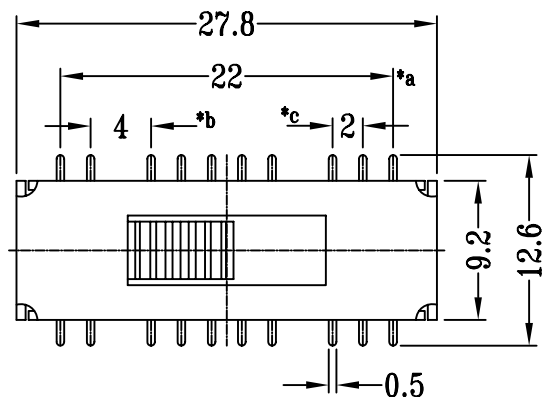
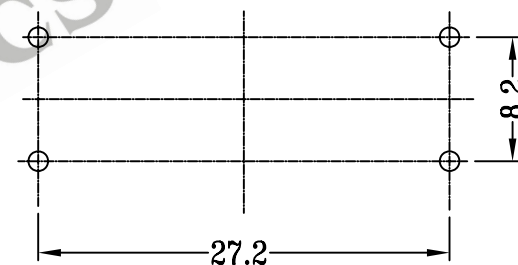

P.C.B LAYOUT

注:带"*"表示关键尺寸(8个)

NO.	PARTS	MATERIALS	Q'TY	FINISH	TOLERANCE UNLESS SPECIFIED	SHENZHEN XIEJIA ELECTRONICS CO.,LTD.					
8						TITLE : VERTICAL SLIDE SWITCH		UNIT : mm	DRWG NO.: XJ-DR-SS44D05-00		
7	CONTACT CLIP	PBS	4	Ag CLAD	WITHIN: 1.5±0.1mm	MODEL: SS-44D05		SCALE: 2 : 1	DWN.	ZHOUYU	2005-8-3
6	SPRING	STEEL WIRE	1	TEMPER	OVER : 1.5±0.2mm				CHK'D	FANGYING	2005-8-3
5	STEEL BALL	STEEL	2	NATURAL					APPD.	KANGXINAN	2005-8-3
4	TERMINAL	BRASS STRIP	20	Ag PLATED OVER Ni PLATED							
3	BASE	PHENOLIC RESIN	1	BLACK							
2	FRAME	STEEL STRIP	1	Ni PLATED							
1	KNOB	POM	1	BLACK							
					ALL MATERIALS MUST BE COMPLIANT TO ROHS						